



Steering, Brake & Suspension Specialists

# #6572DTBK Installation Instructions

## 1963-1972 Deluxe Trac Bar Kit

### Parts List:

- 1 ea Left Lower Shim
- 1 ea Right Lower Mount
- 1 ea 35" Adjustable Trac Bar
- 1 ea 5/8-18x3 Gr. 5 Bolt
- 1 ea 5/8 Lock Nut

### Note:

This kit works with original trailing arms and with CPP tubular trailing arms (#6072TTA).

### Instructions:

1. Remove the track bar. Save the upper mounting hardware, it will be reused to mount the new track bar.
2. Remove the lower mounting stud from the rear axle housing.
3. Remove the right U-bolt from the trailing arm.
4. Install the lower track bar mount on the right trailing arm.
5. Loosely install the right U-bolt.
6. Remove the left U-bolt from the trailing arm.
7. Install the shim between the left trailing arm and the axle perch.
8. Tighten the left U-bolt.
9. Using the original hardware install the new trac bar in to the upper mount.
10. Using the new hardware install the trac bar in to the lower mount.
11. Set the truck on the ground, and adjust the trac bar so that the rear axle is centered under the truck.
12. Ensure that the lower bracket does not have the lower trac bar bushing in a bind. If the bracket needs to be moved, it can be easily adjusted with a pry bar between the bracket and the trailing arm.
13. Tighten the right U-Bolt and the track bar jam nut.

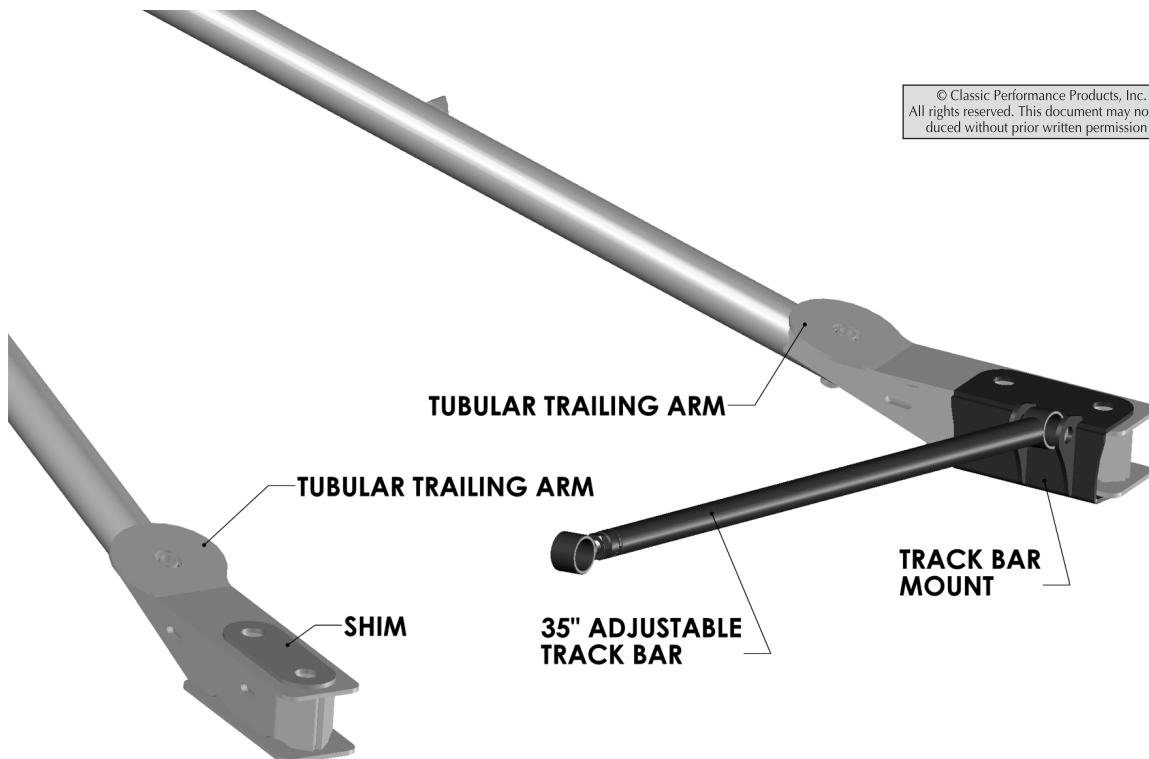

© Classic Performance Products, Inc. 2015  
All rights reserved. This document may not be reproduced without prior written permission of CPP.