



Steering, Brake & Suspension Specialists

#E4852M2IFS-K - Installation Instructions

for 1948-52 Ford F-1 1/2 Ton Truck Mustang II IFS

Thank you for your purchase of one of our full Mustang II Independent Suspension Kits or Crossmember only. If you opted for the full front end suspension, you will notice this is truly one of the most comprehensive all inclusive full hub-to-hub front suspension you can purchase on the market. We are here to answer any installation/technical questions you have during your assembly. For more information, call us at (800) 522-5004, email info@classicperform.com, or visit our website at www.classicperform.com.

This full suspension kit is completely fabricated to make installation a breeze. Each crossmember is fully welded for proper fit and all control arm mounts are factory welded with final welding into the frame necessary. By following this instruction sheet we will provide all the information to properly install. Please read through this entire sheet to familiarize yourself with each step prior to starting your installation.

PLEASE NOTE: The installer needs to make sure that nothing can make contact with a brake hose, caliper, or other brake component at any point through the entire range of steering and suspension movement. The installer also needs to make sure none of the steering or braking components can become bound or jammed at any time through the range of suspension or steering movement.

Instructions:

1. Start with the truck or frame securely on jack stands with the frame set to the same rake angle as the truck will be when completed. (Typically, the frame is at a 3-degree slope so the rear is slightly higher than the front.) If the suspension is installed at the wrong rake angle, you may not be able to align the front end with the correct amount of caster. Remove engine and transmission (if installed) for easier access to the engine bay of your truck. We find it the easiest to have the front sheetmetal off the truck and starting with a bare front frame rail setup with all stock suspension removed. This provides the most amount of space to work with.
2. With only the stock front crossmember in place you will start by boxing the frame rails. The frame must be clean and down to bare metal so the best weld penetration can be made. The boxing plates can either be capped or mounted flush to the upper and lower frame rail. This all depends on the crossmember fitment on your particular frame. Measure the frame width (where the new crossmember centerline will be installed) compared to the new crossmember width and install for the best fit. Prepare the frame rails so the boxing plates can be welded squarely to the frame. The original frame lip will be wider on the bottom compared to the top and may also taper front to rear. Cut or grind so that both are equal width. Start by measuring 17 1/8" back from the original front leaf spring mounting hole (Fig. A) and you will note that the boxing plate will fit the contour of the frame rail. Tack weld the boxing plates in place on both sides. Test fit the new crossmember in place to verify gaps are aligned/square and make adjustments to the boxing plates if necessary. Once the boxing plates are tack welded in the proper position, begin welding into place (Fig. A). It is recommended to weld small sections at a time alternating locations to minimize any warpage. Finish all welds so they are smooth with the frame rails for proper crossmember fitment.

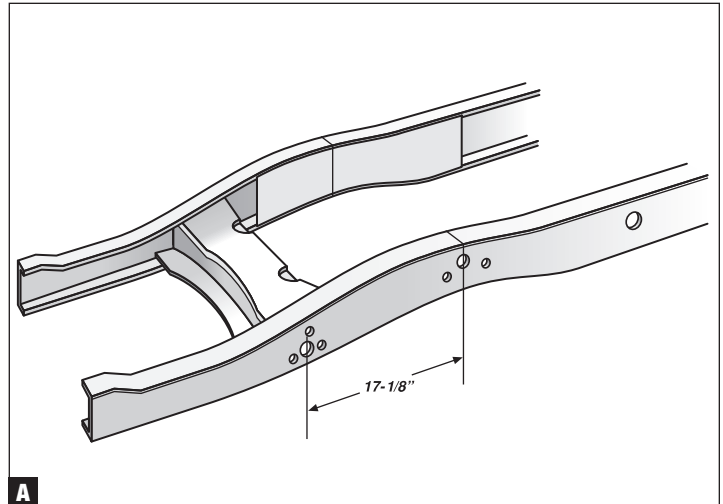

3. Once the frame is prepped, installation of the main suspension crossmember can begin. Start with measuring 17-1/8" back from the center of the front stock shackle hole and clearly mark the new crossmember centerline. Measure and mark both sides of the frame evenly (Fig. A) making sure your mark is vertical (straight up and down) from top to bottom on the framerail on both sides. Next test fit the crossmember into the frame rail making sure it sits properly into the frame. Each truck can be a little different and may require minor trimming and additional fitment to make sure this fits properly.
4. When you are happy with the fitment and the crossmember fits square to the frame, mark the spindle centerline on the crossmember (Fig. B) making sure that your mark is parallel to the axle centerline you marked on the frame. Next is to tack weld the lower crossmember in place.

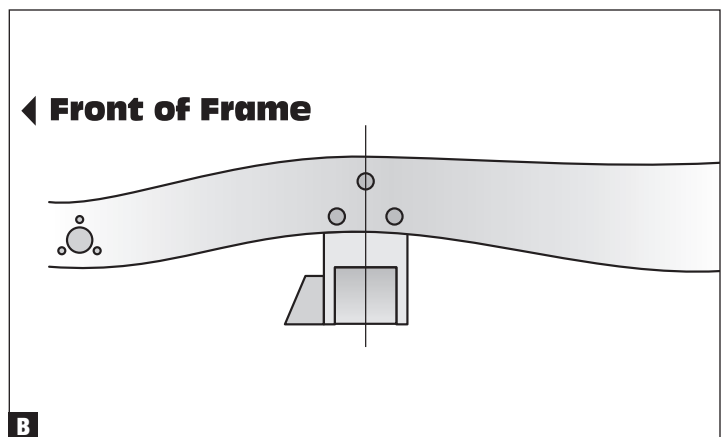

Continued on Next Page



Steering, Brake & Suspension Specialists

#E4852M2IFS-K - Instructions (Continued)

5. Install the upper spring/shock towers; these are both cut at a slight angle. The lower side mounts towards the back of the crossmember to create the proper anti-dive in your suspension. Position the left and right tower on their correct sides of the frame; the round spring and shock mount are outboard, and the slotted flange (upper arm cross shaft mount) is directly above the framerail. Generally, the spring/shock towers locate 1-3/4" forward of the crossmember (basically 0-degree caster); however, you may choose to have more caster, in which case the centerline should be a little to the rear of the crossmember centerline: 3/8" for manual steering and 7/8" for power steering. By offsetting these to the rear you will add caster to the suspension; the caster will increase the steering effort and make the truck more stable at highway speeds. With positive caster the upper ball joint will be rearward of the lower ball joint (Fig. C). This is a very important step to ensure these are installed correctly. Tack weld these in place when you have them perfectly square to the lower crossmember and again making sure the angle is tilted back.

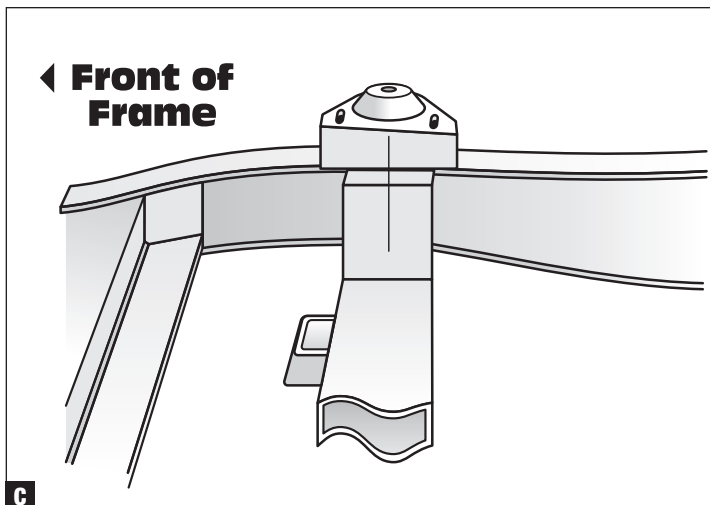

6. With all main parts tack welded into the frame, go through and double check all your measurements and make sure everything is square. Then carefully weld in all main parts to the frame again making sure that you do not heat up the framerails too much, so it is advised to take your time and alternate welding points. If you are not comfortable with the final welding it may be an option to have a certified welder finish this for you.
7. With the main crossmember and components welded in place you can now begin to assemble the front suspension parts. It is advised to fully assemble the suspension, run the brake lines, engine installation, etc prior to painting or powdercoating the frame. This small amount of work will pay off during final assembly as everything will be an easier bolt in and assemble after paint/powdercoat. (For engine and transmission mounting we have these components available if your salesman didn't already offer them: For Small and Big Block Chevy applications we ▶

offer Part #CP4810-S. For Small block Ford applications, we have part #CP4819-S. Both are weld in side mounts. Both engine combinations can run a part #CP4136 transmission crossmember kit to fully install the engine and transmission. Check with CPP or Dealer to obtain these if you don't already have them.)

8. Engine installation is very straightforward (we have provided a separate sheet as a guideline for proper engine/transmission setup as well). The weld-in engine mounts are purposely left long and allow for proper trimming to make the ideal fit into the frame. It is recommended to have the frame and the cab mated together at this point so you can get the engine as far back towards the firewall as possible for the best weight transfer. Using your engine or a mock up block and transmission you can now lower your drivetrain into place to start the fitment of each. When down into the frame in the approximate area it is a good idea to make sure the firewall has just enough clearance for proper distributor adjustment (for Chevy applications). Use this as a guiding point for final placement.
9. Making sure the engine and transmission are perfectly centered between the framerails, allow your engine/transmission to be angled about 4 degrees; the front will be higher than the back.
10. Tack weld the mounts in place and make sure all measurements are correct prior to fully welding the motor mounts in place. Remove your engine and steering rack before fully welding everything in place.
11. Final installation of all main suspension parts is very straight forward. Once your full front crossmember is welded into place you can now move on to installing the main suspension components. First is to fit the lower tubular control arm. There is a right and left lower control arm assembly. Please take note that the lower sway bar mounting holes will be facing forward towards the radiator. The lower control arm cross shaft should fit freely through the arm into the crossmember, making sure that there is a washer both outside portions of the cross shaft where the shaft and the outer bushings meet. If your lower control arm is a little too tight against the cross member you may spring the control arm by placing one end against a metal bench or equivalent and lightly tapping the other end with a rubber mallet to temporarily expand the gap. Doing this will open the control arm enough to fit over the crossmember and allow it to properly torque down seating the inner bushing shaft to the crossmember.
12. Next is to install the upper control arms with the supplied T-bolts. The head of the bolt drops through the top of the crossmember into the slots allowing for camber and caster adjustment for final alignment. When installing the upper control arm make sure the serrated section on the cross shaft is facing down, allowing the cross shaft to grab the crossmember properly. For now, simply snug the bolts until the coil spring is in place.

Continued on Next Page



Steering, Brake & Suspension Specialists

#E4852M2IFS-K - Instructions (Continued)

13. With both upper and lower control arms properly in place you can now install the coil spring and shock. Having the engine and transmission installed at this time will make the steps much easier as the added weight to the frame and vehicle can you make it much easier to get the coil springs in. Be very careful on the steps it takes to install these coil springs and make sure you are using the proper spring compressor. If you do not have one, local tool supply and auto parts stores have them available for purchase. Doing one side at a time; with the coil spring installed, compare your right hand and left hand spindle assembly that comes pre-assembled from CPP making sure the right and left assemblies are on each correct side. Please note that the steering arm on the spindle will face forward to connect to the tie rod end and rack and pinion. You'll also notice there is a spacer supplied with the upper and lower control arms that goes between the castle nut and the spindle to allow the cotter key hole to line up with the ball joint hole. The upper ball joint uses the narrow thin spacer; where the lower ball joint uses the wider thick spacer. With the coil spring in place, attach the spindle to the upper and lower ball joints with each proper spacer in place and torque the castle nuts to 60-65 ft/lbs to seat the tapered shaft properly into the spindle. Then continue to tighten each castle nut until the cotter key hole lines up with the groove in the castle nut. Now you can remove the coil spring compressor and install the shock with supplied hardware. Repeat to the other side of the suspension.

Rack and Pinion Installation:

14. Rack and pinion installation is next. This starts with a little bench work. In your kit there is a rack extension. This extension is to install under the driver's side boot of the rack and pinion. Remove the driver's side boot and take the tie rod off the rack and install the extension between the rack body and the tie rod itself. Use red thread lock for a permanent attachment. Re-install the boot. The attaching hardware is included with the bushing, bolts, nuts and washers. Making sure the flanged edge of the bushing is facing the crossmember attach the rack and pinion. Tighten the supplied hardware to the crossmember. These are a lock nut so tighten just enough to expand the opposite non flanged bushing side even with the washer. Evenly thread the outer tie rods on to the rack and with the rack and pinion centered connects them to the steering arm of the spindle. These are also on a taper so torque to 40-45 ft/lbs and line up the cotter key hole to the castle nut and install the cotter pins. Final Toe adjustment can be made with these installed because of the pivot ball under the rack boot.

Final alignment:

15. Using the following specs, final alignment can now be done on your suspension:

Toe in: +1/16-1/8 (both sides)

Caster: Manual steering: 1-3° positive; Power steering: 4-6° positive

Camber: 0-1/2° negative

GENERAL TORQUE SPECIFICATIONS:

1/4"	grade 5	10 lb/ft	1/4"	grade 8	14 lb/ft
5/16"	grade 5	19 lb/ft	5/16"	grade 8	29 lb/ft
3/8"	grade 5	33 lb/ft	3/8"	grade 8	47 lb/ft
7/16"	grade 5	54 lb/ft	7/16"	grade 8	78 lb/ft
1/2"	grade 5	78 lb/ft	1/2"	grade 8	119 lb/ft
9/16"	grade 5	114 lb/ft	9/16"	grade 8	169 lb/ft
5/8"	grade 5	154 lb/ft	5/8"	grade 8	230 lb/ft

NOTE: With 18" and larger wheels we recommend 1/2" wheel studs. The larger the wheel diameter, the greater the force is on the wheel studs. Please inquire about replacement wheel stud kits available from CPP.

Optional Items Available:

#M2PSH-RT (power steering hoses)	#CPP brake line kits	#4852BB2/BB4 (booster kits)
#CPP U-joints	#4852FBB2/BB4	
#CP4810-S (engine mounts)	#TC-series of steering columns	
#CP4819-S	#CPFM (floor mount)	
#CP4136 (transmission crossmember)	#CPCD-2/3/4 (column drops)	

Visit Us Online to Order or Download our New Catalog:

www.ClassicPerform.com