

Steering, Brake & Suspension Specialists

#6472TCA-UK Installation Instructions

for 1964-72 "A" Body Tubular Upper Control Arms

Parts List:

- 1 ea Left Upper Control Arm Assembly
- 1 ea Right Upper Control Arm Assembly

Instructions:

1. Remove the original upper control arms.
2. Install the new upper control arm assemblies. CPP recommends using new ball joints (part # FA487) and bump stops (part #3773361).
3. Have the car professionally aligned.

Note:

The ball joint is mounted to the bottom side of the control arm.

Warning:

Do not remove the cross shaft bolts. They are installed with Loctite. Removing the cross shaft bolts will void the warranty.

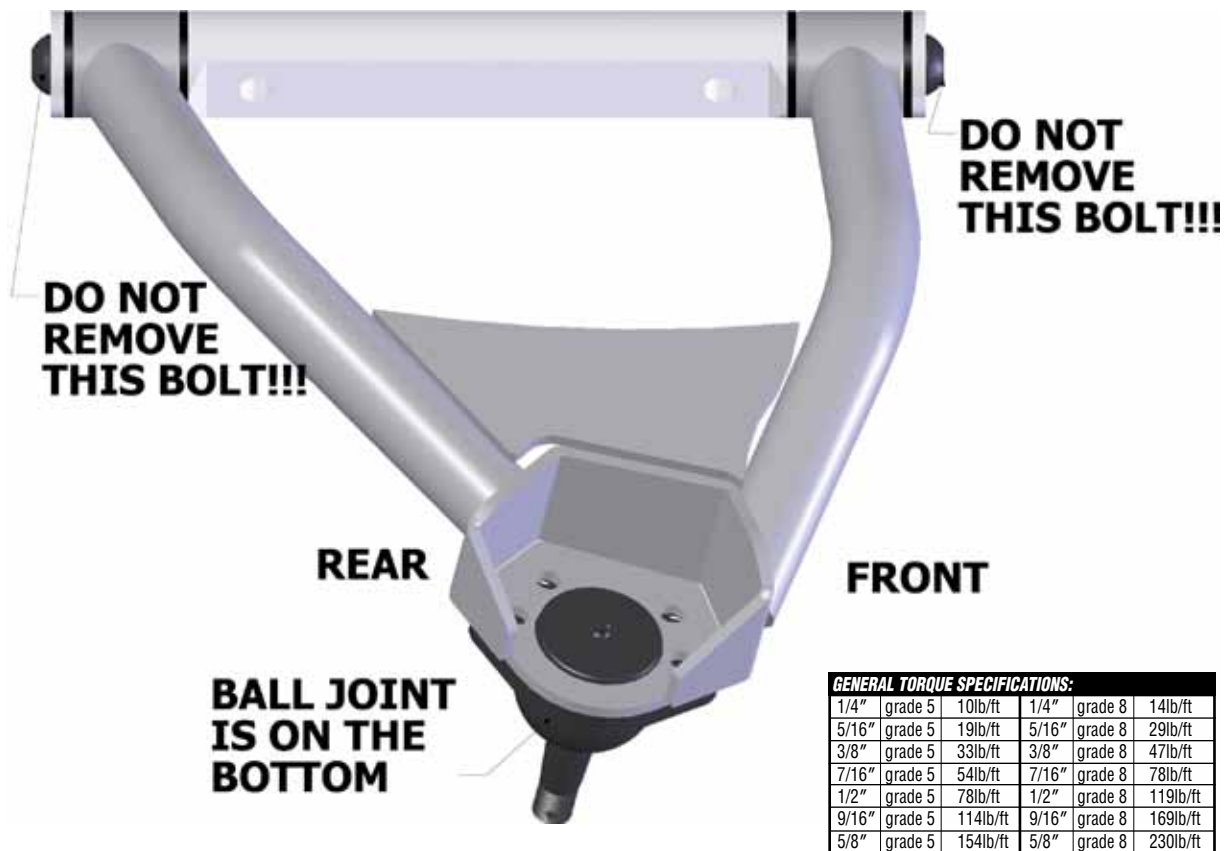

GENERAL TORQUE SPECIFICATIONS:					
1/4"	grade 5	10lb/ft	1/4"	grade 8	14lb/ft
5/16"	grade 5	19lb/ft	5/16"	grade 8	29lb/ft
3/8"	grade 5	33lb/ft	3/8"	grade 8	47lb/ft
7/16"	grade 5	54lb/ft	7/16"	grade 8	78lb/ft
1/2"	grade 5	78lb/ft	1/2"	grade 8	119lb/ft
9/16"	grade 5	114lb/ft	9/16"	grade 8	169lb/ft
5/8"	grade 5	154lb/ft	5/8"	grade 8	230lb/ft

For technical help call Classic Performance Products Monday thru Friday 8:30am to 5:00pm at (714) 522-2000.

Classic Performance Products, Inc. 714.522.2000 | fax 714.522.2500
 378 E. Orangethorpe Ave. | Placentia, CA 92870 | www.classicperform.com