



Steering, Brake & Suspension Specialists

#6769FLK-OM Installation Instructions

for 1967-69 Camaro Disc Brake Conversion Line Kit

Instructions:

1. Remove your old single master cylinder.
2. Install your new master cylinder, booster, and valve assembly. Remove and discard the original master cylinder line. The original left and right front brake lines may be left in place.
3. Install **Line 1** from rear of proportioning valve to rear of original distribution block as shown. Some models will use 1/4" line, others will use 3/16" line. Discard line not needed.
4. Install **Line 2** from bottom of proportioning valve to front driver side of original distribution block as shown.
5. Install **Line 3** from front of original distribution block to left front (drivers) brake hose.

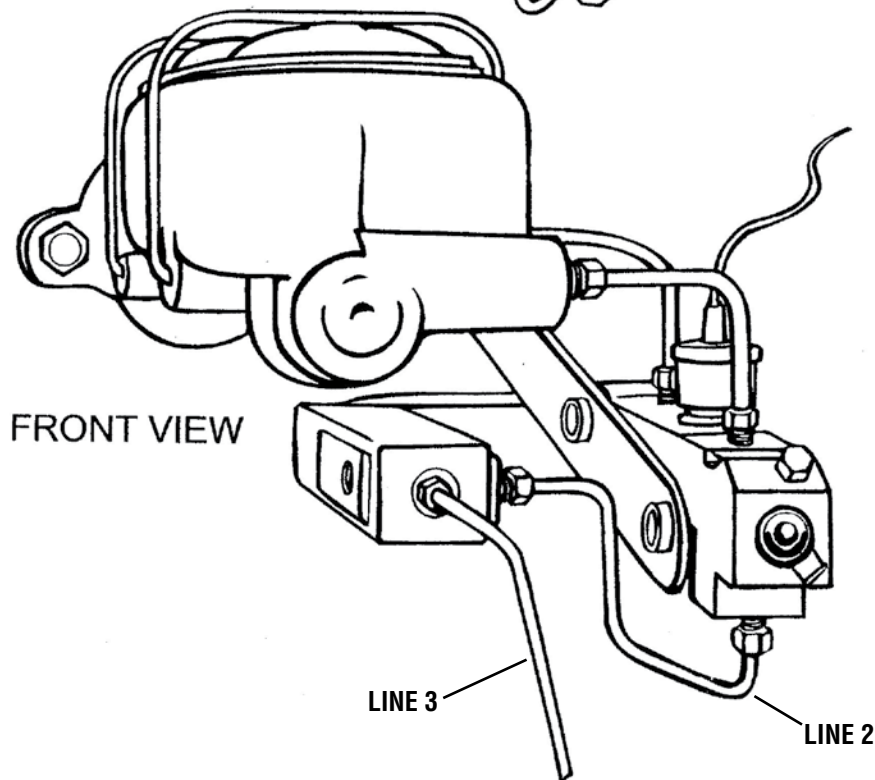
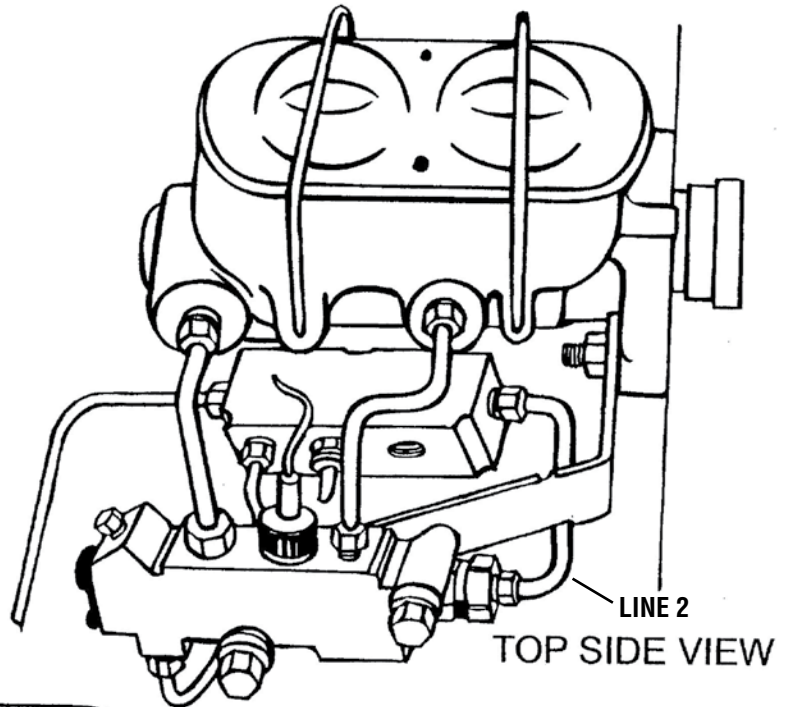

Classic Performance Products, Inc. 714.522.2000 | fax 714.522.2500
378 E. Orangethorpe Ave. | Placentia, CA 92870 | www.classicperform.com